

NEW

Concrete T-Bar/Edging from **Loxscreen**

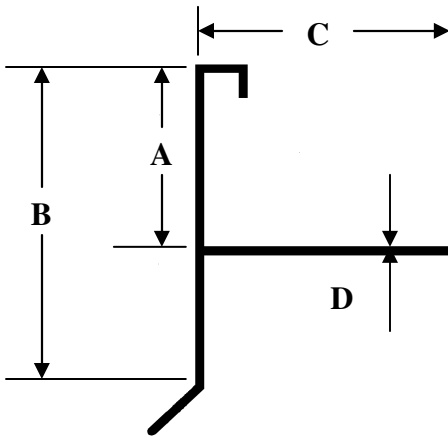

Die Number	A Pour Depth	B Overall Face	C Nail Flange	D Thickness	Wt. / Ft.
AA016502	1.441	2.551	1.875	.050	.325
AA016690	1.470	2.947	1.875	.050	.349
AA018412	1.500	2.536	2.000	.050	.338
AA019521	2.000	3.310	1.875	.050	.382
OA043739	2.000	3.484	1.875	.058	.450
AA019520	3.000	4.975	1.875	.050	.479
OA043740	3.000	5.105	2.000	.063	.629

Die Number	A Pour Depth	B Overall Face	C Nail Flange	D Thickness	Wt. / Ft.
AA016474	1.441	2.937	1.875	.045	.317
AA016191	1.500	2.875	2.055	.058	.382
AA018411	1.500	2.925	2.000	.050	.330

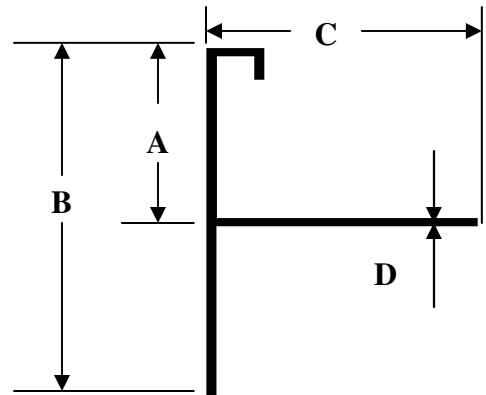

***** FEATURES *****

Uniform pour depth.

Drip lip channels water away from fascia board.

Return channel locks into pour to prevent separation.

Mill finish. (painted finish available)