

# INDEX

<u>Catalog Item Number</u>	<u>Page</u>
AA000164	3
AA000238	3
AA007454	7
AA008121	3
AA008123	14
AA008148	13
AA008222	13
AA008771	13
AA009215	13
AA011498	13
AA016395	9
AA018147	12
AA018148	3
AA018149	3
AA018150	4
AA018151	12
AA018379	2
AA018419	5
AA018650	13
AA018695	13
AA018714	3
AA018787	10
AA018791	4
AA018792	5
AA018793	5
AA018802	13
AA018822	13
AA019053	7
AA019054	7
AA019055	11
AA019056	6
AA019090	14
AA019112	2
AA019114	2
AA019260	8
AA019452	5
AA019486	12
AA019539	3
AA019595	6
AA019596	7
AA019695	4
AA019859	6
AA020078	13
AA020151	12
AA020152	6
AA020153	5
AA020379	13
AA020530	12
AA020531	3
AA020688	13
AA020693	2
AA020753	4
AA020972	5
OA002175	12
Post & Rail Assembly	1

Post & Rail  
Stiffener Assembly

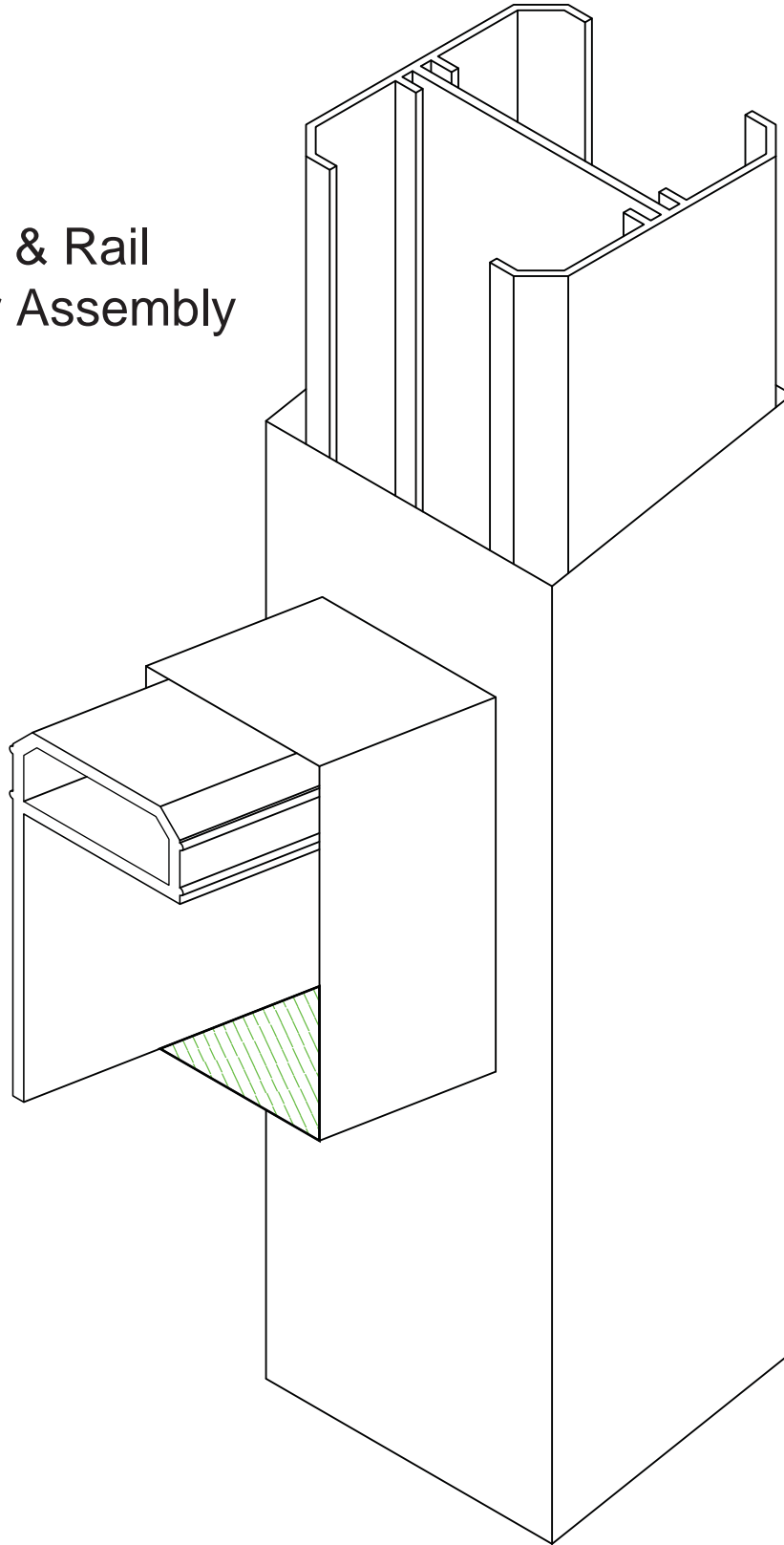

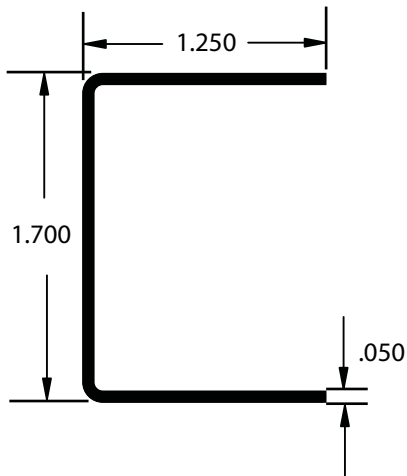

**AA019114 Rail Support**  
24' Length / AE Finish  
w/ft. .242

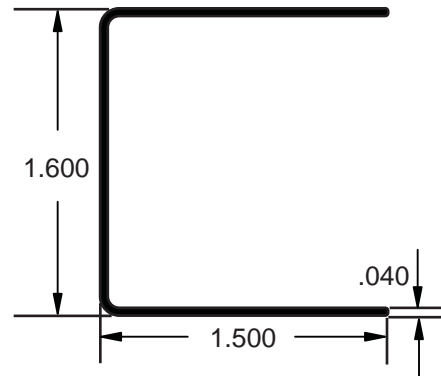

**AA020693 Rail Support**  
24' Length / AE Finish  
w/ft. .214

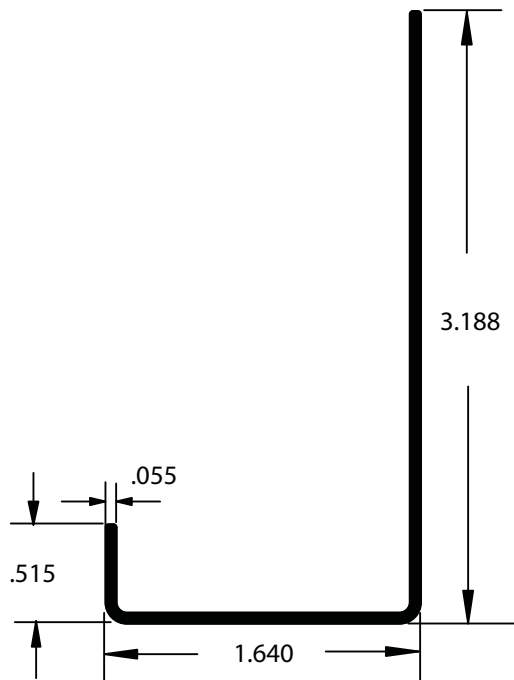

**AA019112 J Channel Support**  
24' Length / AE Finish  
w/ft. .341

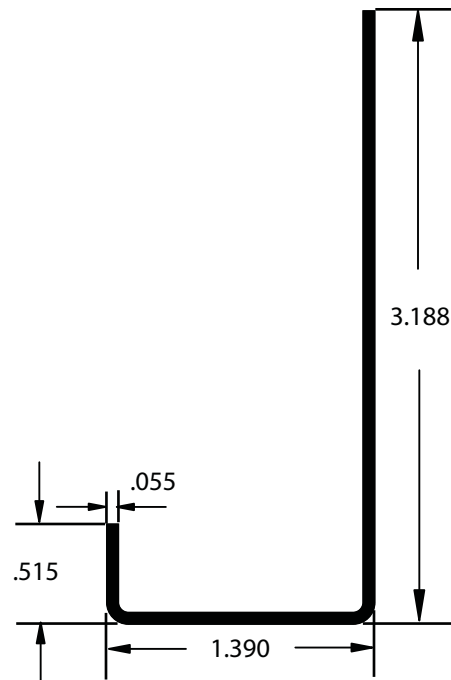

**AA018379 J Channel Support**  
24' Length / AE Finish  
w/ft. .324

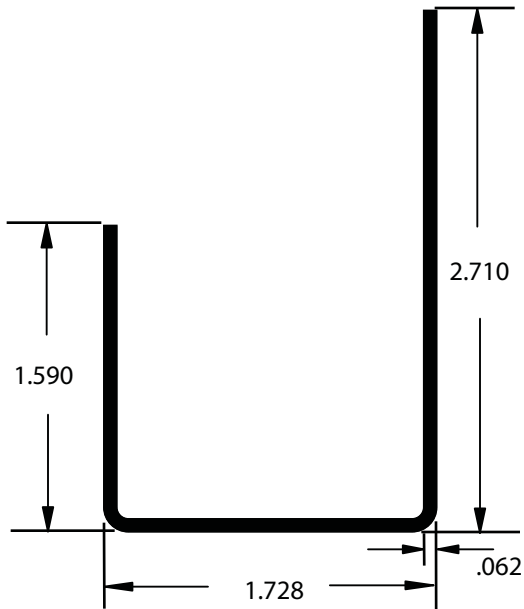

**AA018149 J Channel Support**  
24' Length / AE Finish  
w/ft. .433

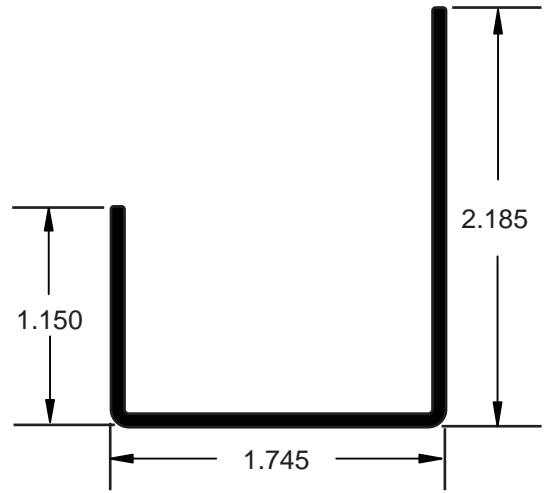

**AA020531 J Channel Support**  
24' Length / AE Finish  
w/ft. .410

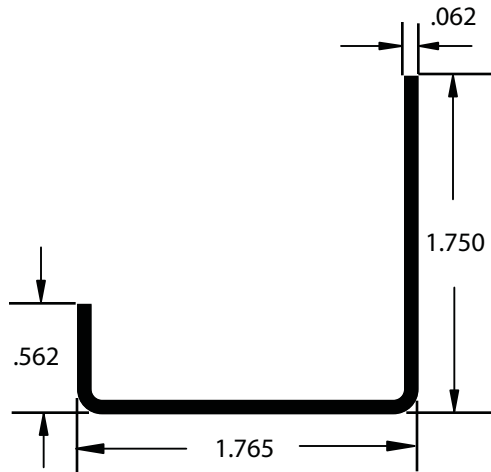

**AA019539 J Channel Support**  
24' Length / AE Finish  
w/ft. .288

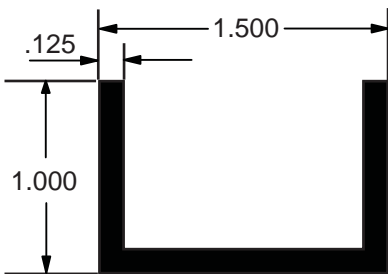

**AA008121 U Channel Support**  
24' Length / AE Finish  
w/ft. .487

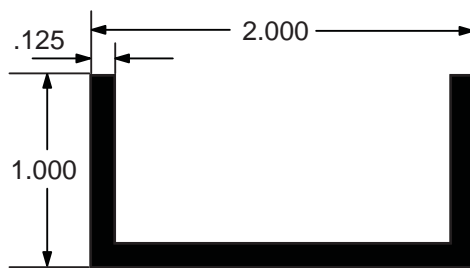

**AA000164 U Channel Support**  
24' Length / AE Finish  
w/ft. .563

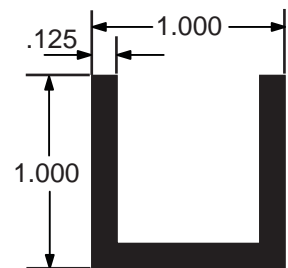

**AA000238 U Channel Support**  
24' Length / AE Finish  
w/ft. .413

All shapes are shown in actual size.  
Lengths other than 24' may be available.

# Fence System

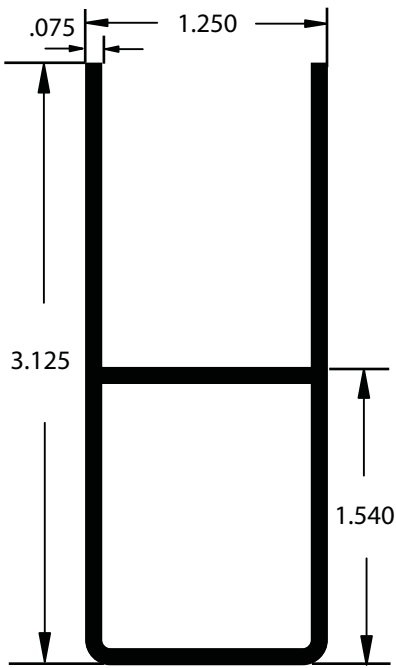

**AA018150 U Channel Support**  
24' Length / AE Finish  
w/ft. .754

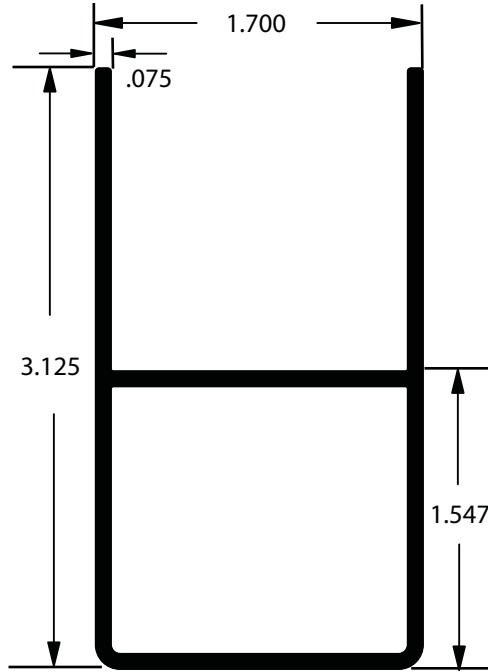

**AA019695 U Channel Support**  
24' Length / AE Finish  
w/ft. .835

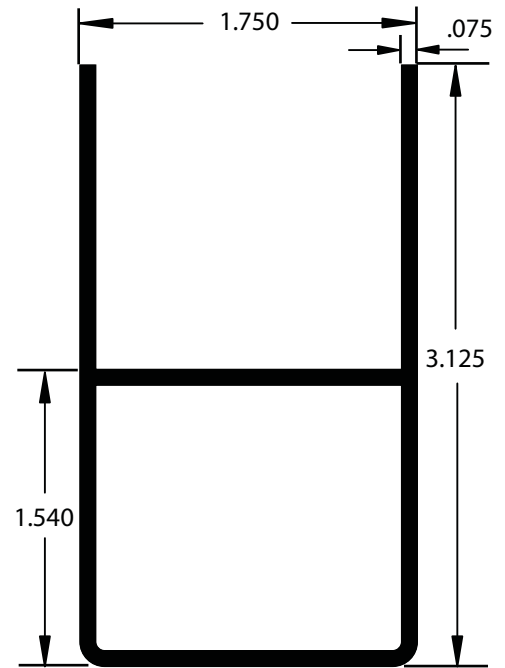

**AA018714 U Channel Support**  
24' Length / AE Finish  
w/ft. .844

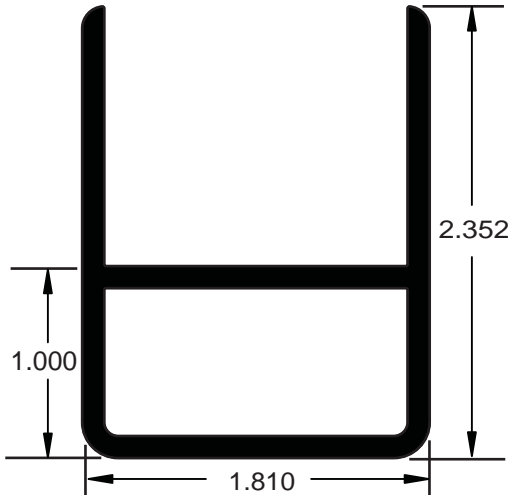

**AA020753 U Channel Support**  
24' Length / AE Finish  
w/ft. 1.063

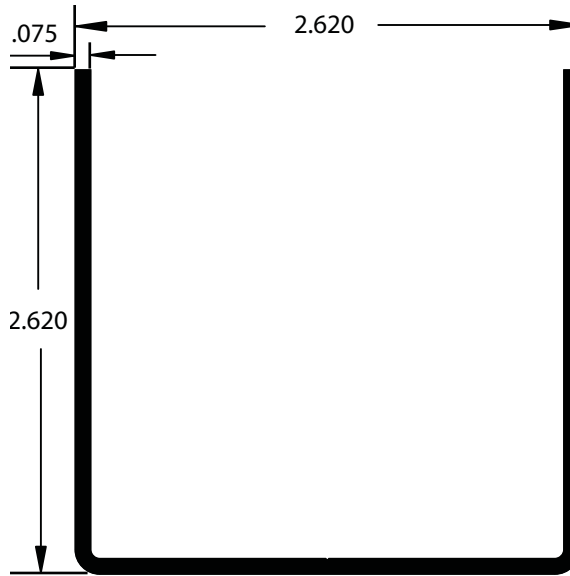

**AA018148 U Channel Support**  
24' Length / AE Finish  
w/ft. .688

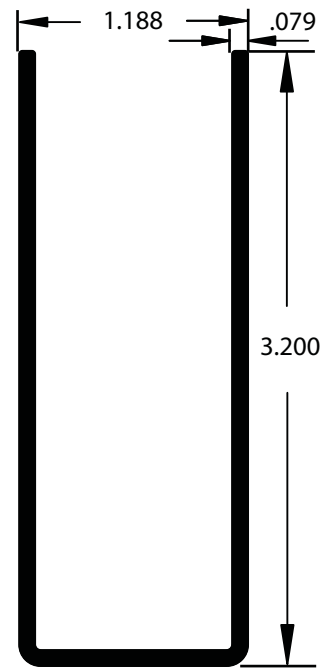

**AA018791 U Channel Support**  
24' Length / AE Finish  
w/ft. .698

All shapes are shown in actual size.

Lengths other than 24' may be available.

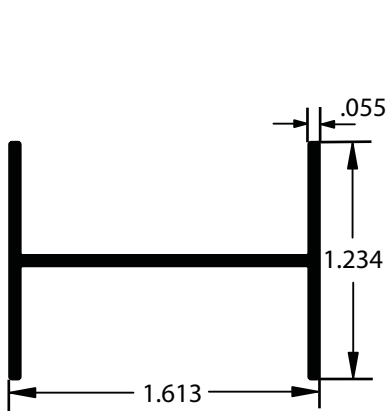

**AA019452 H Stiffener**  
24' Length / AE Finish  
w/ft. .262

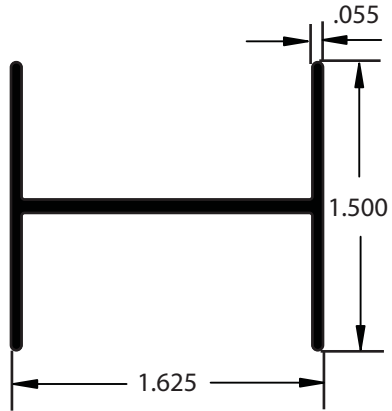

**AA020153 H Stiffener**  
24' Length / AE Finish  
w/ft. .324

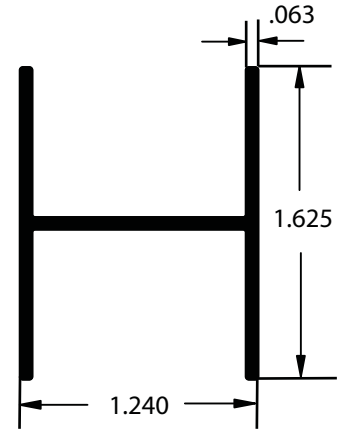

**AA018793 H Stiffener**  
24' Length / AE Finish  
w/ft. .329

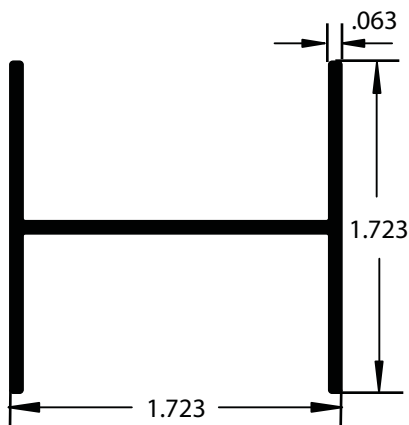

**AA018792 H Stiffener**  
24' Length / AE Finish  
w/ft. .378

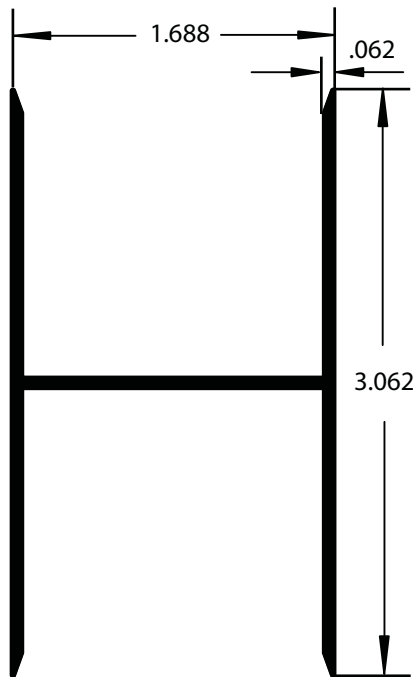

**AA018419 H Stiffener**  
24' Length / AE Finish  
w/ft. .558

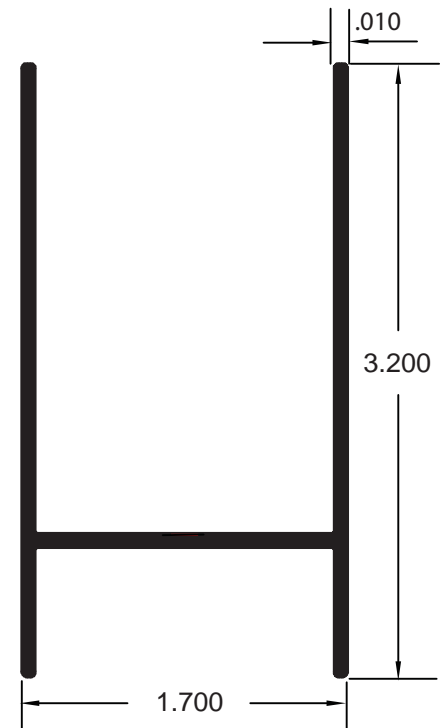

**AA020972 H Stiffener**  
24' Length / AE Finish  
w/ft. .714

All shapes are shown in actual size.  
Lengths other than 24' may be available.

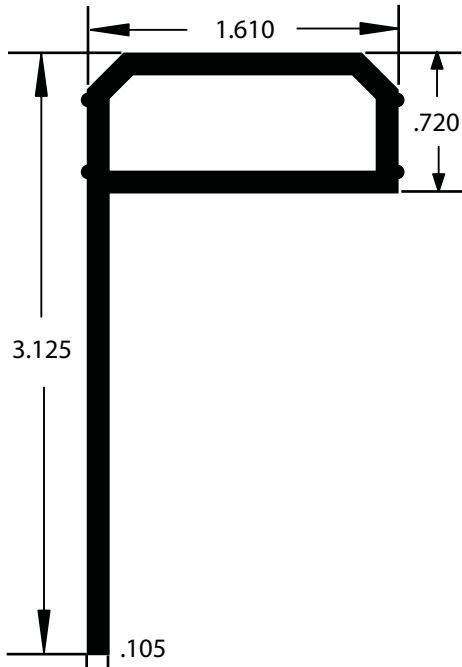

**AA019056 P Stiffener**  
 24' Length / AE Finish  
 w/ft. .821

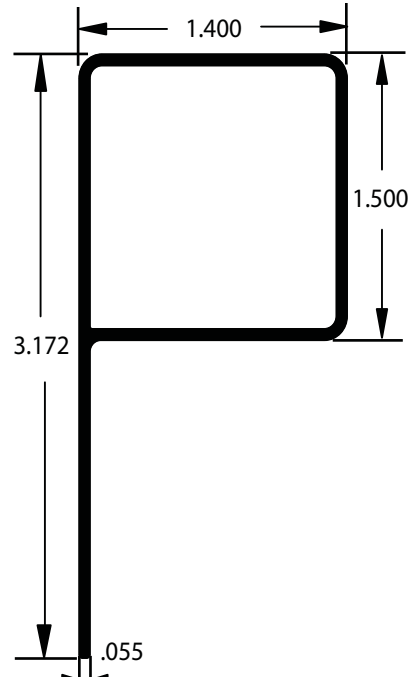

**AA019859 P Stiffener**  
 24' Length / AE Finish  
 w/ft. .472

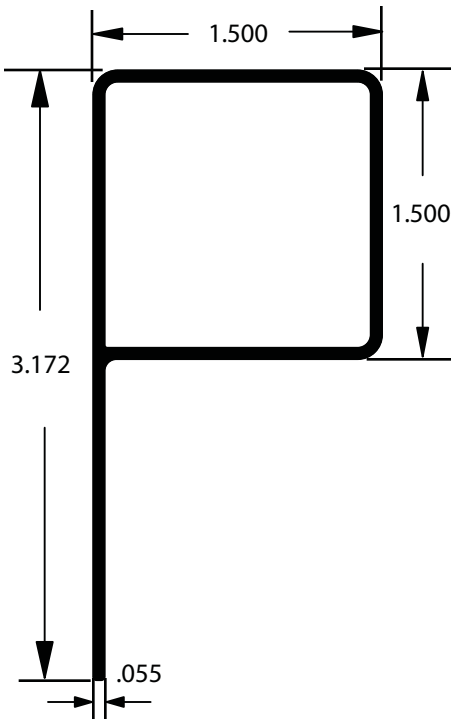

**AA019595 P Stiffener**  
 24' Length / AE Finish  
 w/ft. .485

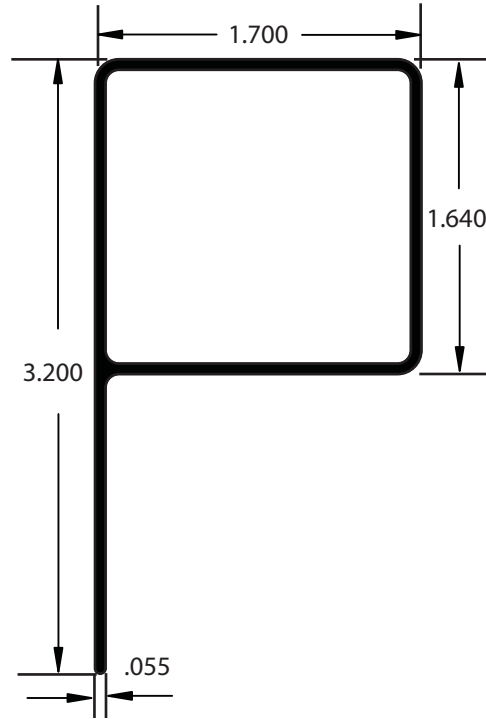

**AA020152 P Stiffener**  
 24' Length / AE Finish  
 w/ft. .523

All shapes are shown in actual size.

Lengths other than 24' may be available.

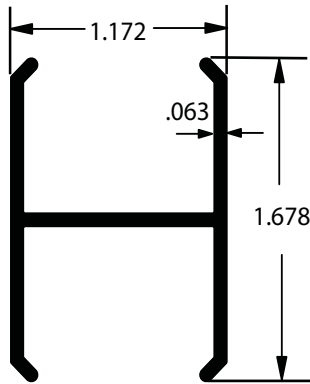

**AA019596 HOA Stiffener**  
24' Length / AE Finish  
w/ft. .341

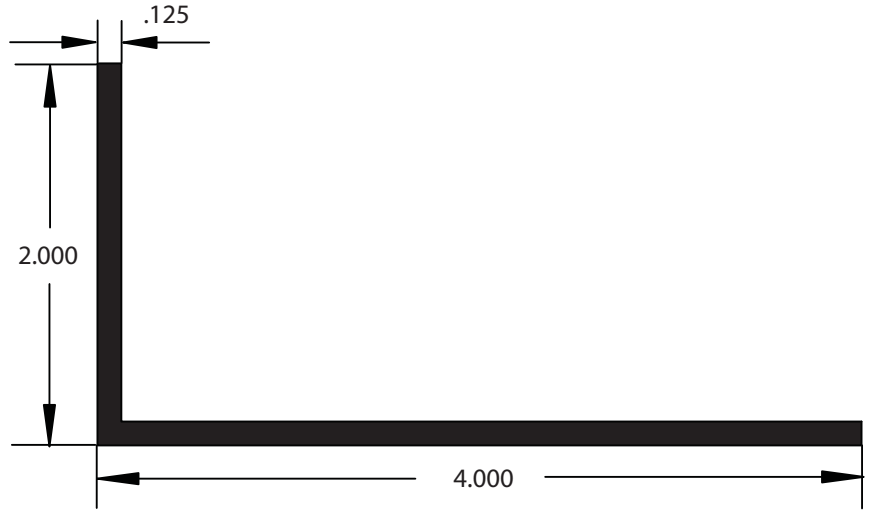

**AA007454**  
2 x 4 x 1/8 Mounting Angle  
(used with 4" & 5" post stiffeners)

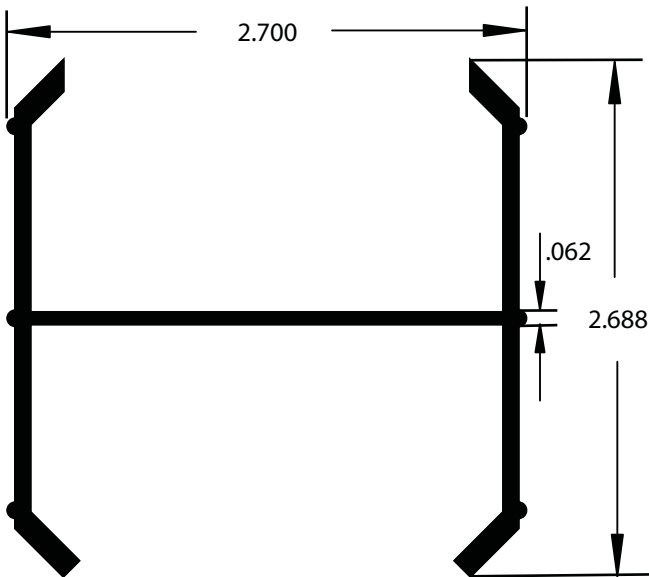

**AA019053 3" Post Stiffener**  
24' Length / AE Finish  
w/ft. .775

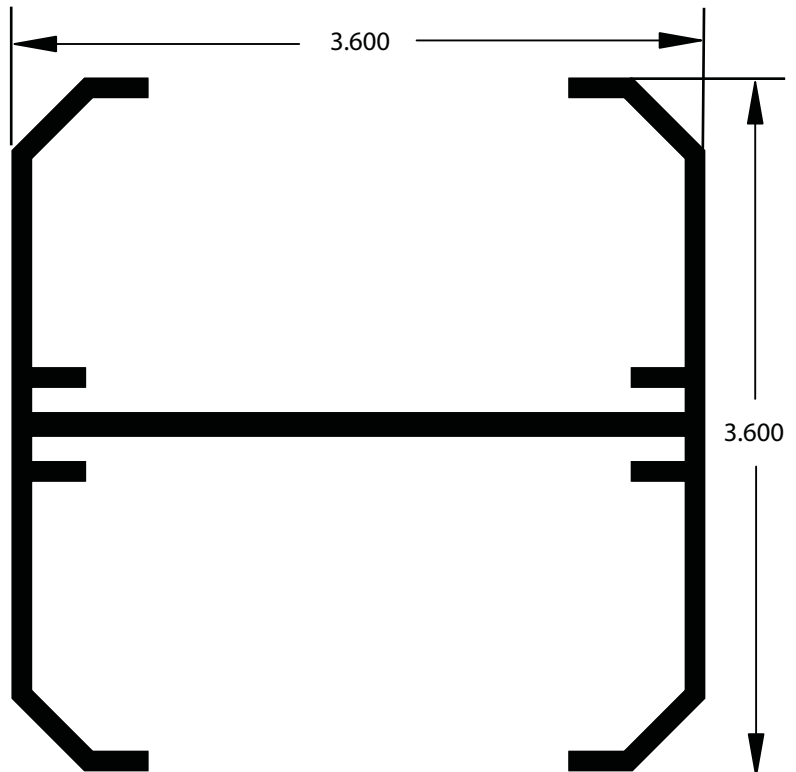

**AA019054 4" Post Stiffener**  
24' Length / AE Finish  
wall thickness .100  
w/ft. 1.591

All shapes are shown in actual size.  
Lengths other than 24' may be available.

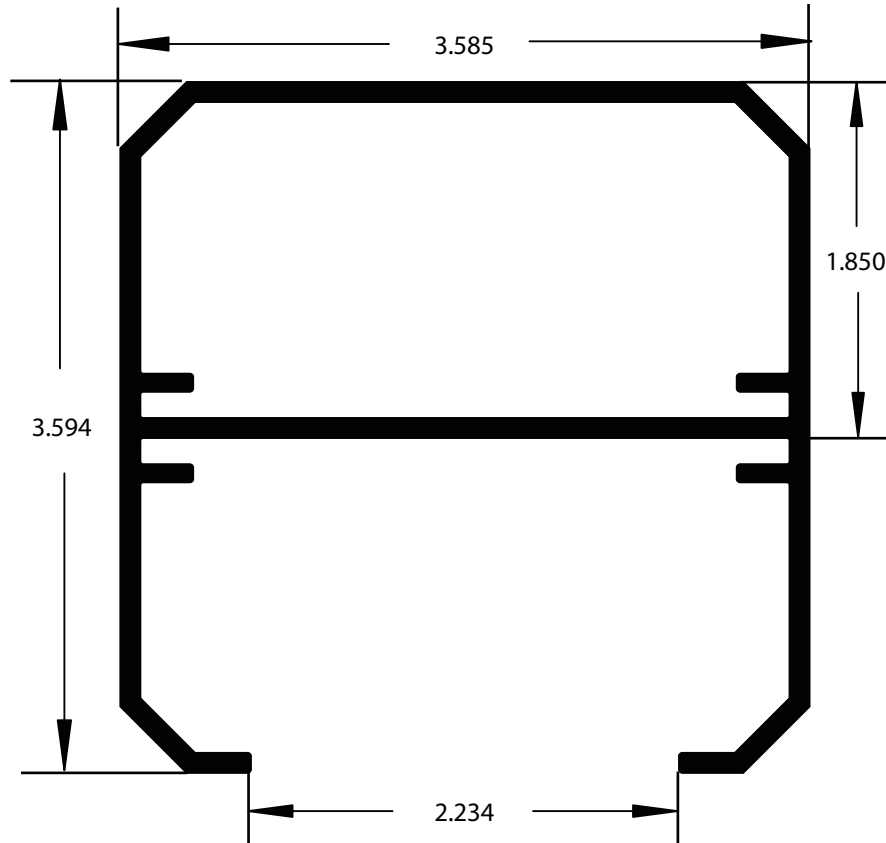

**AA019260 4" Post Stiffener with Closed End**  
24' Length / AE Finish  
wall thickness .100  
w/ft. 1.843

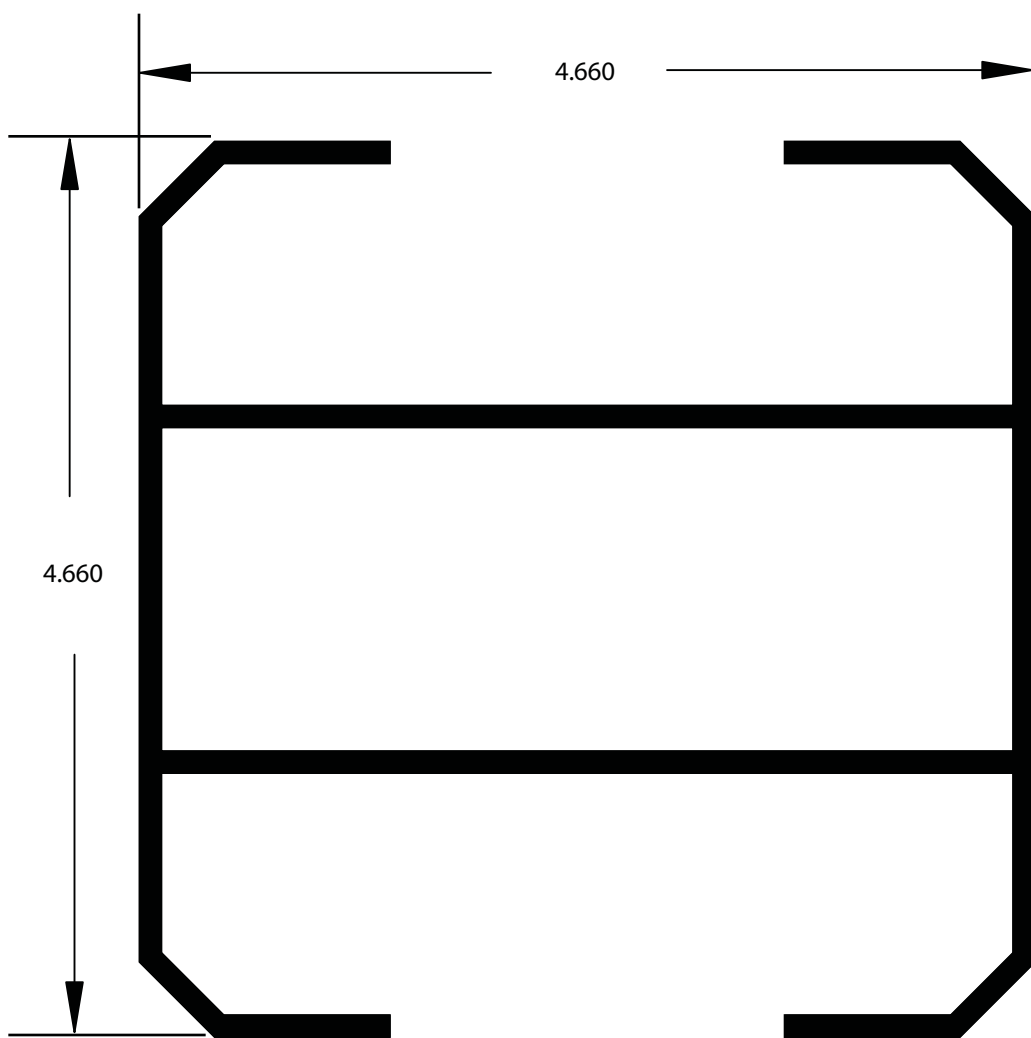

**AA016395 5" Hollow Post Stiffener**

24' Length / AE Finish

wall thickness .110

w/ft. 2.920

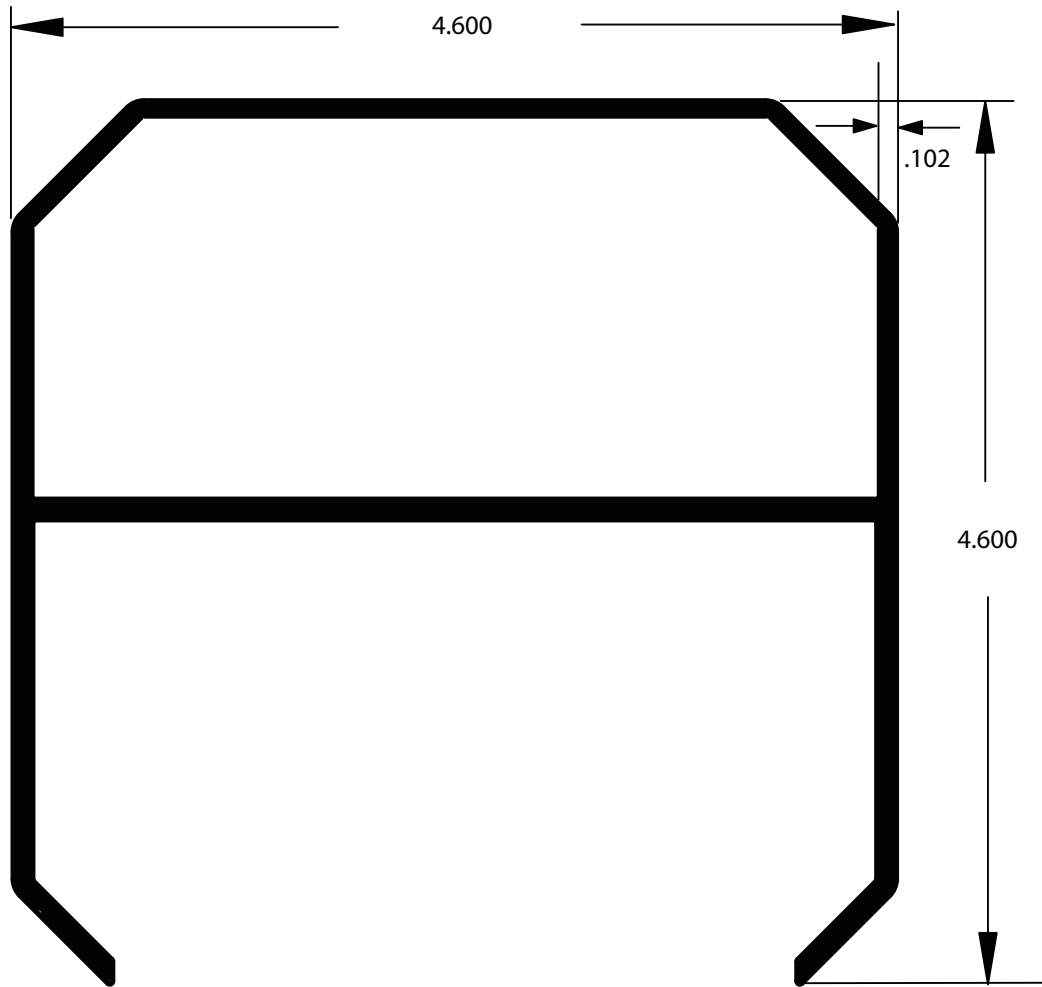

**AA018787 5" Post Stiffener with Enclosed End**

24' Length / AE Finish

wall thickness .102

w/ft. 2.148

All shapes are shown in actual size.

Lengths other than 24' may be available.

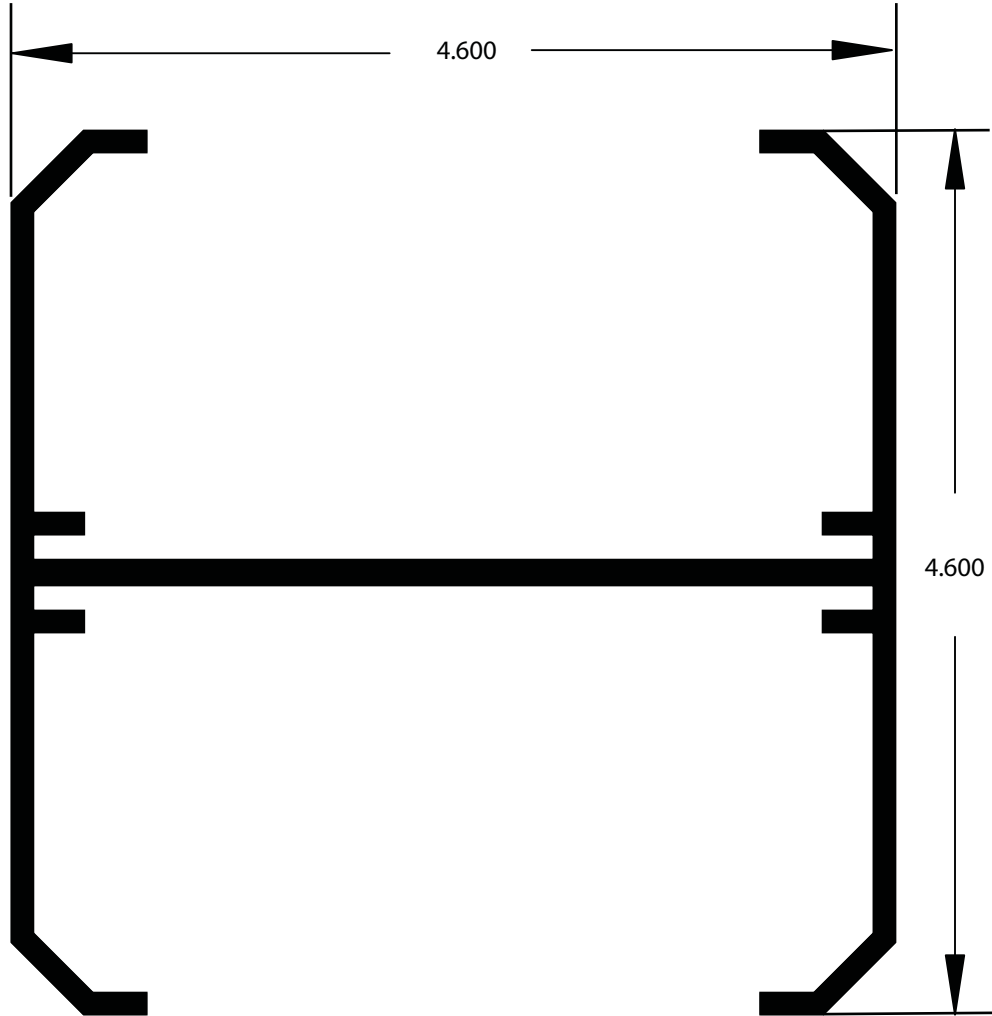

**AA019055 5" Post Stiffener**

24' Length / AE Finish  
wall thickness .110  
w/ft. 2.243

# Fence System

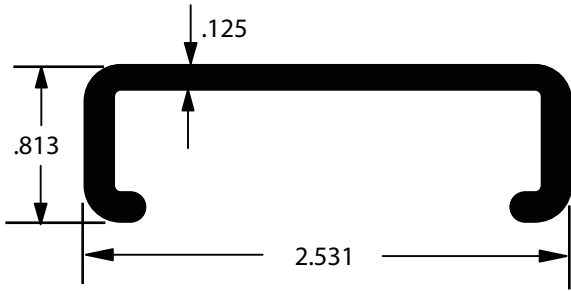

**AA019486 Top Rail Stiffener**  
24' Length / AE Finish  
w/ft. .646

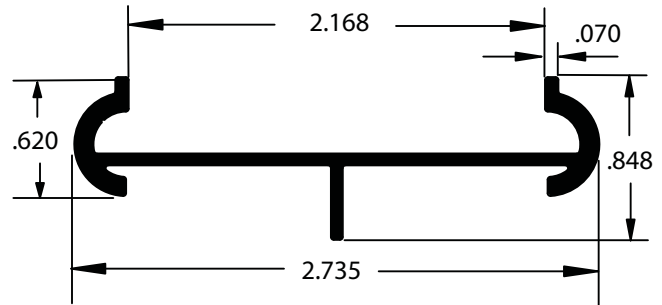

**OA002175 Top Rail Support**  
24' Length / AE Finish  
w/ft. .397

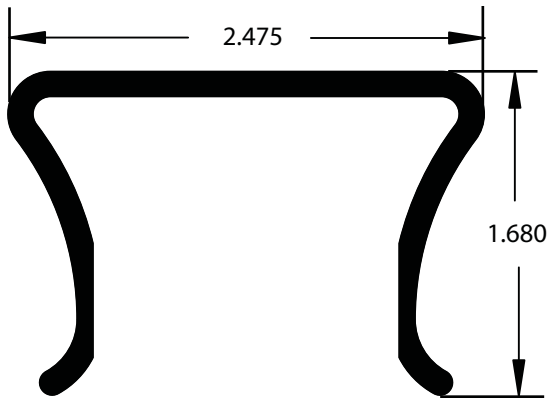

**AA018151 Sculptured Channel**  
24' Length / AE Finish  
w/ft. .814

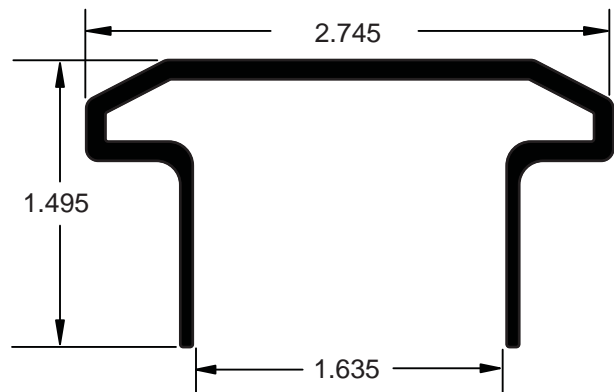

**AA020530 Top Rail Stiffener**  
24' Length / AE Finish  
w/ft. .654

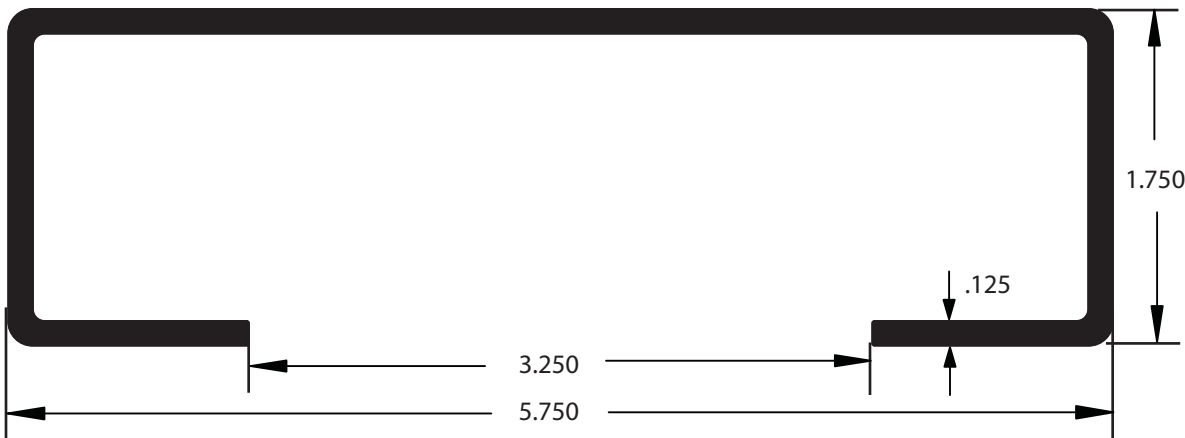

**AA020151 Top Rail Stiffener**  
24' Length / AE Finish  
w/ft. 1.675

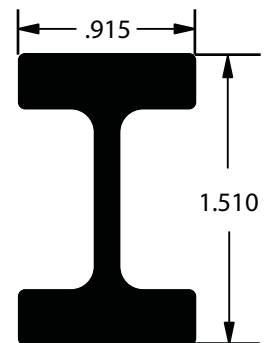

**AA018147 I Beam**  
24' Length / AE Finish  
w/ft. .772

All shapes are shown in actual size.

Lengths other than 24' may be available.

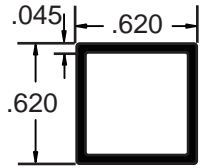

**AA020078 Square Tube**  
w/ft. .121

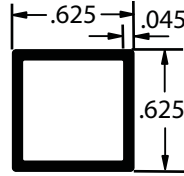

**AA018650 Square Tube**  
w/ft. .125

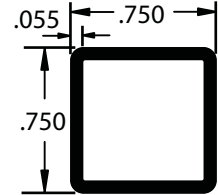

**AA018802 Square Tube**  
w/ft. .180

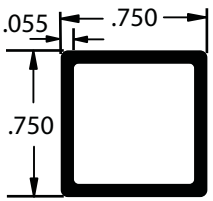

**AA018695 Square Tube**  
w/ft. .184

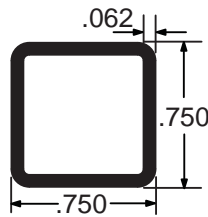

**AA008771 Square Tube**  
w/ft. .193

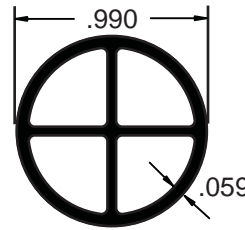

**AA020688 Quad Pole**  
used for pool barrier fencing  
w/ft. .302

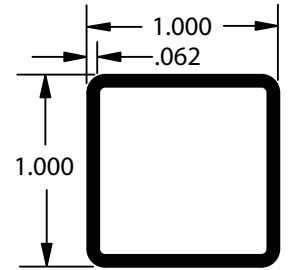

**AA009215 Square Tube**  
w/ft. .271

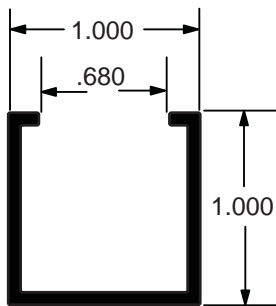

**AA020379 Horizontal Picket Rail**  
w/ft. .239

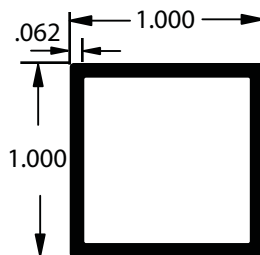

**AA008148 Square Tube**  
w/ft. .280

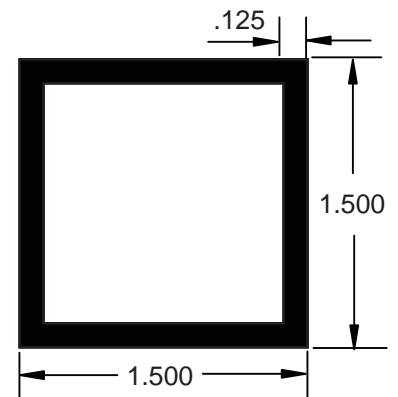

**AA008222 Square Tube**  
w/ft. .826

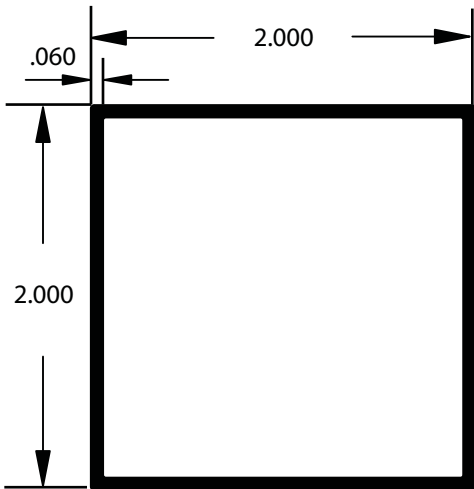

**AA011498 Square Tube**  
w/ft. .559

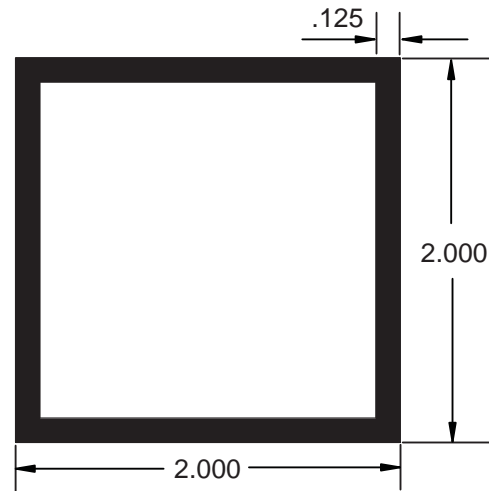

**AA008123 Square Tube**  
w/ft. 1.126

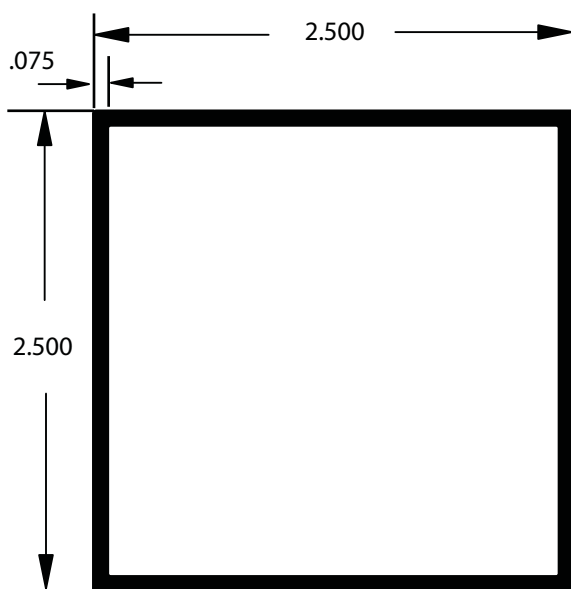

**AA018822 Square Tube**  
w/ft. .874

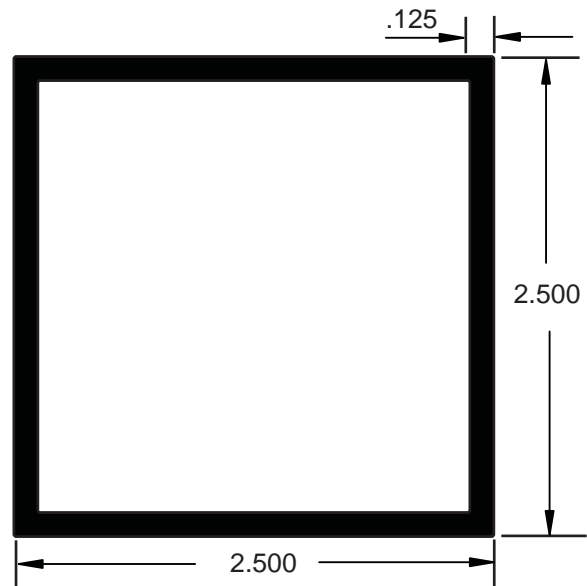

**AA019090 Square Tube**  
w/ft. 1.426

All shapes are shown in actual size.  
Lengths other than 24' may be available.

# Terms & Conditions

**1. CONTRACT BETWEEN BUYER AND SELLER:** A written order and acknowledgment shall constitute the contract between Buyer and Seller, and said Contract may not be amended or rescinded except by written agreement by both parties, referring expressly to this contract.

**2. WARRANTY:** Seller warrants that merchandise sold to Buyer shall be free from defects in material and workmanship and shall conform to specifications. **EXCEPT FOR SUCH WARRANTY, THE SELLER DISCLAIMS ANY AND ALL OTHER WARRANTIES OF ANY KIND WHATSOEVER, INCLUDING WITHOUT LIMITATION, ANY WARRANTY OF MERCHANTABILITY OR FITNESS FOR PARTICULAR PURPOSE AND INCLUDING BUT NOT LIMITED TO ANY ORAL OR WRITTEN DESCRIPTION OF THE PRODUCTS, THEIR CHARACTERISTICS OR PROPERTIES OTHER THAN THAT SPECIFICALLY STATED IN THE FOREGOING LIMITED WARRANTY. SELLER SHALL HAVE NO LIABILITY FOR CONSEQUENTIAL OR INCIDENTAL DAMAGES AS A RESULT OF THE SALE OF ITS MERCHANDISE.** In the event that its merchandise is not as warranted, Buyer's sole remedy will be, at Seller's election, replacement of the merchandise or return of the purchase price. Prior written approval from the Seller must be secured before returning any merchandise for credit.

**3. TOLERANCES:** Standard Commercial tolerances apply unless otherwise specified.

**4. PRICE:** Prices are based on existing conditions and are subject to change, at our discretion, at any time prior to order shipment. Unless otherwise specified, all prices are based on quantity shipped per release, with Buyer accepting over-run or under-run on each individual item based on standard shipping tolerances. Exact control of quantity shipped must be specified as a requirement of said contract.

**5. CREDIT:** All shipments shall be subject to the approval of Seller's Credit Department. If, in the sole judgment of the Seller, the financial responsibility of the Buyer is unsatisfactory, or becomes impaired, or if Buyer fails to make any payment in accordance with the terms of the contract, then Seller may defer or decline to make any shipments except upon receipt of satisfactory security or cash payments in advance, or Seller may terminate the contract.

**6. TAXES:** All prices are subject to the net additions of all Federal, State, or Municipal taxes or charges which may be established or levied upon or assessed against the merchandise under contract.

**7. SHIPMENTS:** Unless otherwise specified, title to all merchandise, and the risk of loss, shall pass to the Buyer upon delivery by the Seller to the transportation carrier at the shipping point or the actual transfer of possession to the Buyer, whichever is earlier.

**8. DELAYS:** Seller cannot be held liable for loss or damage arising from delay in fulfilling or failure to fulfill any accepted order in accordance with its terms where such delay or failure is caused by shortage of materials, delays of carriers, embargoes, fires, floods, strikes, riots, wars, acts of God, or other causes beyond our control.

**9. RETURNED MATERIAL AUTHORIZATION:** Seller must be notified within 10 days after delivery of Buyer's request to return merchandise. Upon receipt of Seller's authorization, merchandise must be returned within 30 days in accordance with Seller's shipping instructions. Merchandise must be returned in exactly the same condition as in which it was received by Buyer. Handling and restocking fees will be charged to Buyer's account.

**10. CANCELLATION:** Said contract is subject to cancellation only upon Seller's acceptance of such cancellation in writing and the effective date of cancellation shall be the date of such acceptance. Payment of cancellation charges shall be made by Buyer upon receipt of statement of same. Cancellation charges shall not exceed the purchase price of the canceled portion of the contract.

**11. EQUIPMENT:** Any equipment (including jigs, process dies and tools, etc.) which Seller constructs or acquires specifically for use on Buyer's order shall be the sole property of Seller, whether or not they are charged to Buyer's account. Die charges are for exclusive use of extrusion tooling and are not subject to refund. Dies which indicate no activity for two years or more will be scrapped without notice and replacement cost will be for Buyer's account.

**12. PATENT PROTECTION:** Seller agrees to indemnify Buyer against any claims or liabilities for or by reason of alleged patent infringement arising from the manufacture or sale of any merchandise furnished Buyer hereunder, except where the specifications, process, design or method of manufacture originated with Buyer, in which event Buyer agrees to indemnify Seller in like manner.

# THE *Loxscreen* COMPANY, INC.

Contact our Service Center near you for more information.

---

## **Corporate Office**

---

1630 Old Dunbar Road / PO Box 4004 (29171) / West Columbia, South Carolina 29172  
(803) 822-8200 / FAX (803) 822-8547  
www.loxscreen.com

## **Loxscreen MetalSource®**

---

### TEXAS

PO Box 5126 / Arlington, Texas 76005 / 400 N. Great SW Parkway / Arlington, Texas 76011  
Metro 640-4456 / All other areas (817) 649-2771 / FAX (817) 649-1760 / 800-222-4629

### GEORGIA

6360 Button Gwinnett Drive / Atlanta, Georgia 30340 / (770) 448-7878 / FAX (770) 729-9478  
800-843-5692

### MISSOURI

1503 Harry S. Truman Blvd. / Caruthersville, Missouri 63830 / (573) 333-0098 / FAX (573) 333-0574  
800-323-8314

### OHIO

100 Westheimer Drive / Middletown, Ohio 45044 / (513) 539-2255 / FAX (513) 539-2288  
800-432-4672

### NORTH CAROLINA

PO Box 29 / 2300 Old Durham Road / Roxboro, North Carolina 27573 / (336) 599-3111 / FAX (336) 597-8821  
800-682-9586

### FLORIDA

1600 E. Lake Mary Boulevard / Sanford, Florida 32773 / (407) 322-1031 / FAX (407) 323-5918  
Toll Free in Florida 800-330-5699

### SOUTH CAROLINA

Metal Distributors, Inc.  
PO Box 4004 / West Columbia, SC 29171-4004 / 1630 Old Dunbar Road / West Columbia, SC 29172  
(803) 822-1600 / FAX (803) 822-8070

### ILLINOIS

1500 Scottsdale Court / Suite 100 / Elgin, IL 60123 / (847) 488-1007 / FAX (847) 488-1427 /  
Toll Free 877-488-1007

SOME ITEMS MAY NOT BE CARRIED IN STOCK.  
PRICES ARE AVAILABLE UPON REQUEST.